

SKETCH/AREA TABLE ADDENDUM

File No 26017531

Property Address **26-36-12-02 7**

City _____ County **BREVARD** State _____ Zip _____

Owner **SFR 11-18-02 MO136128 \$169,700**

Client _____ Client Address **6200 HALYARD COURT**

Appraiser Name **GLENN LEGGE** Inspection Date **VIERA (PERMITS)**

NOTE: VERIFY ALSCN. CONFLICTING MEASUREMENTS IN POOL PACKAGE.

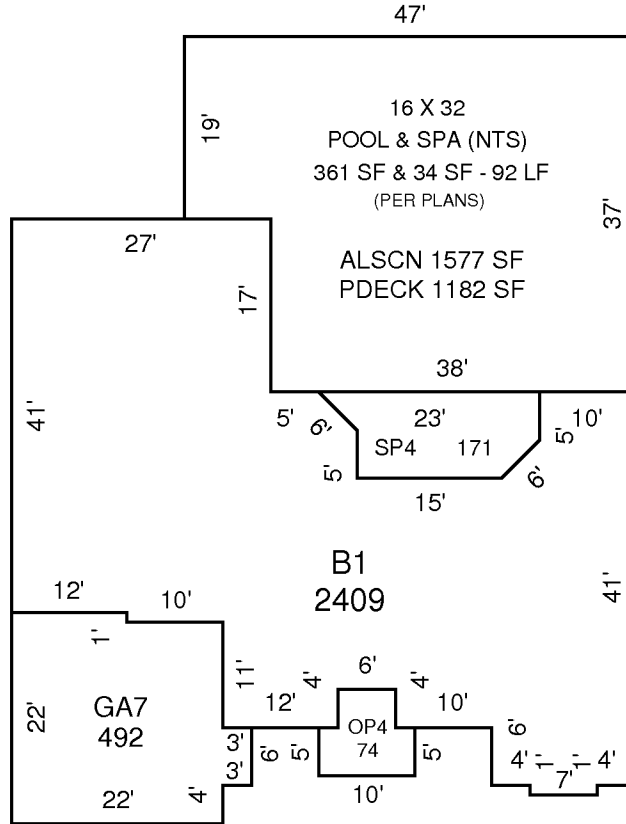

DRAWN: GNL 4-9-03

AREA CALCULATIONS SUMMARY

Code	Description	Factor	Net Size	Perimeter	Net Totals
B1	B1-100	1.00	2409	271	2409
GA7	GA-60	1.00	492	94	492
OP4	OP-30	1.00	74	38	74
SP4	SP-40	1.00	171	59	171
NON	NON-CALCULATED AREA	1.00	1577	168	1577
