

SKETCH/AREA TABLE ADDENDUM

DATE 9/29/10

RE # 2601131

SUBJECT

PARCEL ID	26 360377 E. 5.		
CITY	MELBOURNE	COUNTY	BREVARD
		STATE	FL
		ZIP	32940
PERMIT #	NA		
MARKET AREA	9	ADDRESS	1166 CONTINENTAL AVE
APPRAISER NAME	EWI	BRANCH OFFICE	PALM BAY

IMPROVEMENTS SKETCH

EST FROM PICTOMETRY

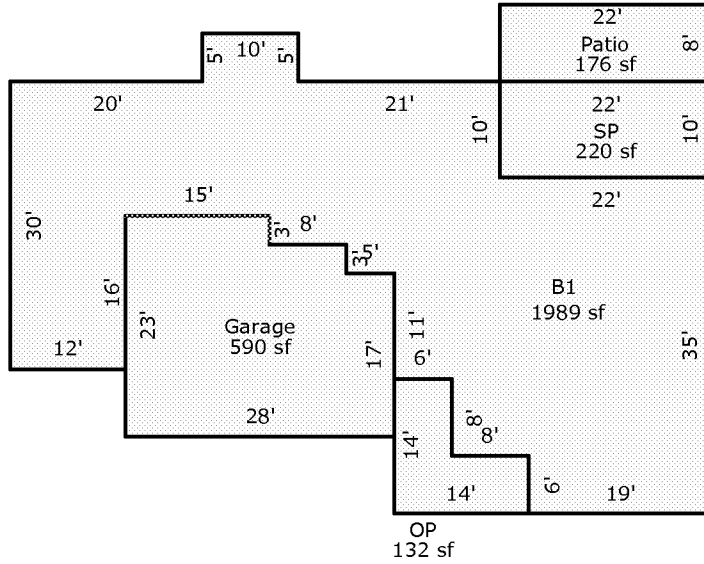

Scale: 1 = 20

AREA CALCULATIONS

AREA CALCULATIONS SUMMARY

Code	Description	Factor	Net Size	Perimeter	Net Totals
B1	B1	1.00	1989	278	1989
GA	Garage	1.00	590	102	590
OP	OP	1.00	132	56	132
PT	Patio	1.00	176	60	176
SP	SP	1.00	220	64	220

Comment Table 1

--	--

Comment Table 2

Comment Table 3

--	--