

SKETCH/AREA TABLE ADDENDUM

DATE 8/12/10

RE # 2536379

SUBJECT	PARCEL ID 25 362826 A 2	CITY ROCKLEDGE	COUNTY BREVARD	STATE FL	ZIP 32955
	PERMIT # T0210060	ADDRESS 3042 BELLWOOD CIR			
	MARKET AREA 09	APPRaiser NAME PHK			
	BRANCH OFFICE PALM BAY				

NO F/C ALL ESTIMATED W/PICTOMETRY

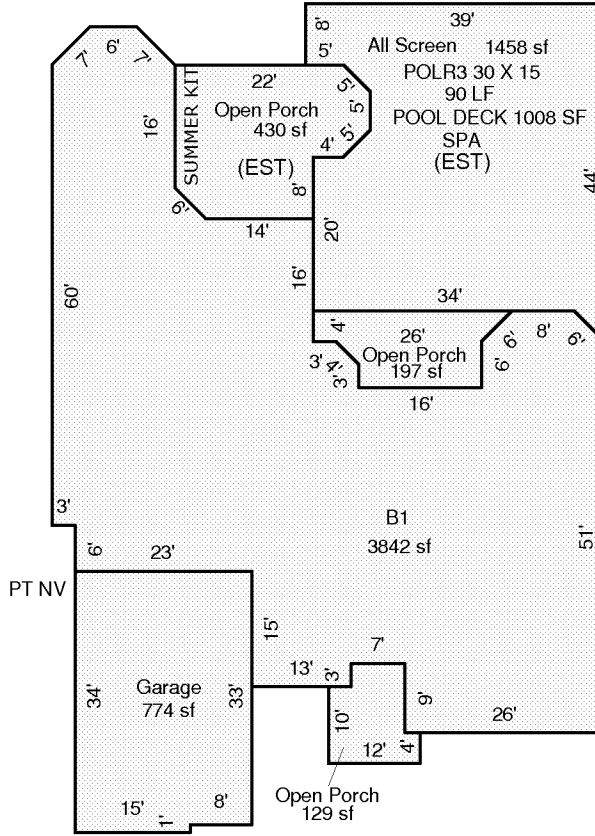

Scale: 1 = 25

AREA CALCULATIONS	AREA CALCULATIONS SUMMARY					
	Code	Description	Factor	Net Size	Perimeter	Net Totals
	B1	B1	1.00	3842	339	3842
	GA	Garage	1.00	774	114	774
	OP	Open Porch	1.00	129	50	
	Open Porch	1.00	197	68		
	Open Porch	1.00	430	85	755	
ALSCN	All Screen	1.00	1458	175	1458	
Comment Table 1						
Comment Table 2			Comment Table 3			