

SKETCH/AREA TABLE ADDENDUM

File No 25302571

SUBJECT

Property Address 25-36-12-RJ 5	County BREVARD	State	Zip
City			
Owner SFR 4-10-01 OCO108926 \$256,000	Client Address 453 WATERSIDE DRIVE		
Client	Inspection Date VIERA (PERMITS)		
Appraiser Name GLENN LEGGE			

IMPROVEMENTS SKETCH

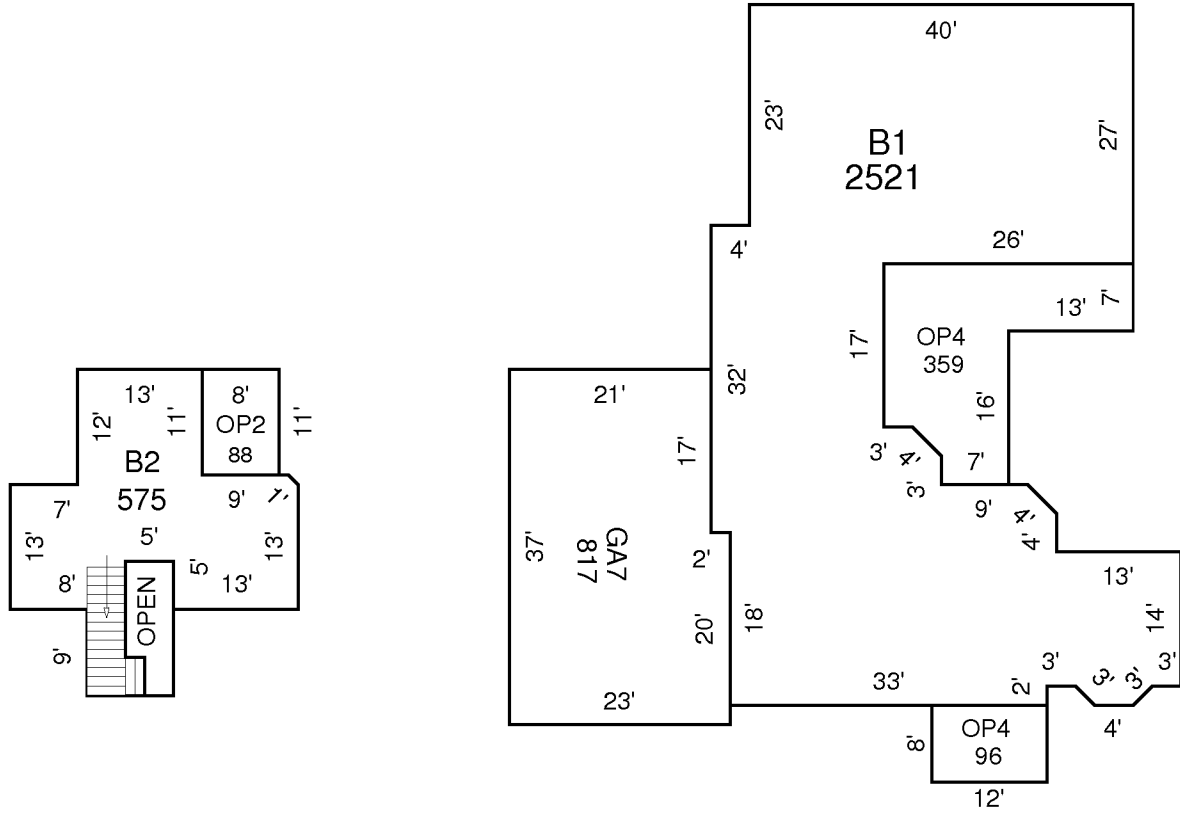

DRAWN: GNL 8-22-01

AREA CALCULATIONS

AREA CALCULATIONS SUMMARY

Code	Description	Factor	Net Size	Perimeter	Net Totals
B1	B1-100	1.00	2521	294	2521
B2	B2-100	1.00	575	141	575
GA7	GA-60	1.00	817	120	817
OP4	OP-30	1.00	96	40	
	OP-30	1.00	359	96	455
OP2	OP-20	1.00	88	38	88
NON	NON-CALCULATED AREA	1.00	4	10	
	NON-CALCULATED AREA	1.00	62	38	66
