

SKETCH/AREA TABLE ADDENDUM

File No 25228781

SUBJECT

Property Address **25-37-10-82-117-9**

City **Cocoa Beach**

County **BREVARD**

State **FL**

Zip **32931**

Owner

Client **32**

Client Address **164 Cedar Avenue**

Appraiser Name **BDC/SNJ**

Inspection Date **Titusville**

IMPROVEMENTS SKETCH

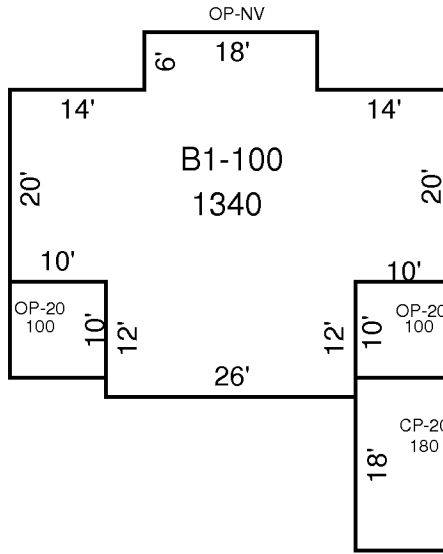

AREA CALCULATIONS

AREA CALCULATIONS SUMMARY

Code	Description	Factor	Net Size	Perimeter	Net Totals
B1	B1-100	1.00	1340	168	1340
OP2	OP-20	1.00	100	40	
	OP-20	1.00	100	40	200
CP2	CP-20	1.00	180	56	180