

SKETCH/AREA TABLE ADDENDUM

File No 2519524

SUBJECT

Property Address	25 3722DP E 4		
City	COCOA BEACH	County	BREVARD
		State	FL
		Zip	32931
Owner			
Client	18	Client Address	1760 BAY SHORE DRIVE
Appraiser Name	M09 DRAW / M12 FIELD	Inspection Date	MI

IMPROVEMENTS SKETCH

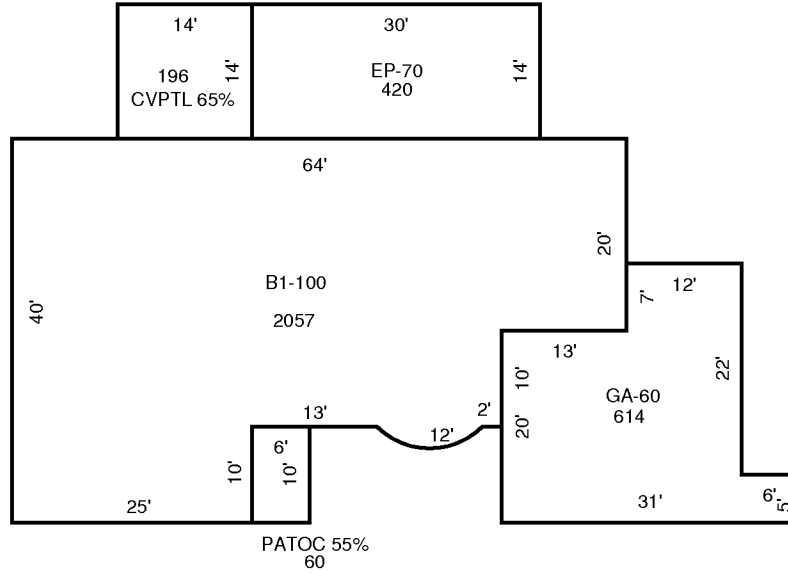

AREA CALCULATIONS

AREA CALCULATIONS SUMMARY

Code	Description	Factor	Net Size	Perimeter	Net Totals
B1	B1-100	1.00	2057	209	2057
GA7	GA-60	1.00	614	116	614
OP4	CVPTL 65%	1.00	196	56	196
EP4	EP-70	1.00	420	88	420
PT	PATOC 55%	1.00	60	32	60