

# SKETCH/AREA TABLE ADDENDUM

File No 2511364

Property Address 25 36 24 IX 14

City MERRITT ISLAND

County Brevard

State FL

Zip 32952

Owner

Client 19

Client Address 1260 SHADY LA

Appraiser Name M25 DRAW/M16 FIELD

Inspection Date MI

SUBJECT

IMPROVEMENTS SKETCH

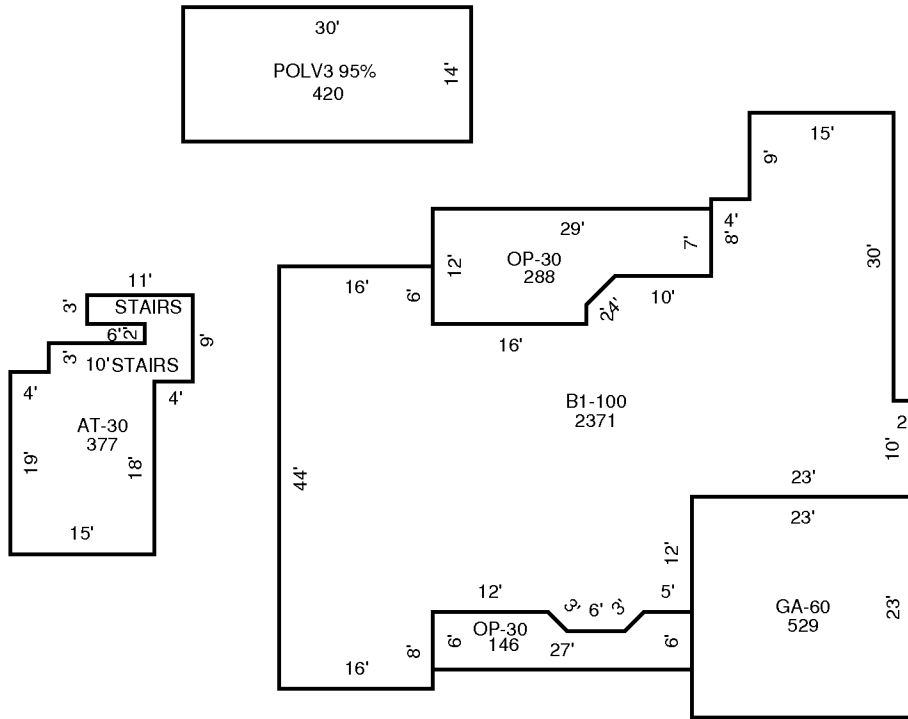

AREA CALCULATIONS

## AREA CALCULATIONS SUMMARY

Code	Description	Factor	Net Size	Perimeter	Net Totals
B1	B1-100	1.00	2371	264	2371
GA7	GA-60	1.00	529	92	529
OP4	OP-30	1.00	146	68	
	OP-30	1.00	288	80	433
AT1	AT-30	1.00	377	104	377
POOL	POLV3 95%	1.00	420	88	420

## Comment Table 1

--	--

## Comment Table 2

## Comment Table 3

--	--