

# SKETCH/AREA TABLE ADDENDUM

Parcel No 1-15-08

File No 2507227

Property Address 25 3610NC 60

City ROCKLEDGE

County BREVARD

State FL

Zip 32955

Owner x

Client 09

Client Address 65 River Ridge Dr.

Appraiser Name DZC

Inspection Date Titusville

SUBJECT

IMPROVEMENTS SKETCH

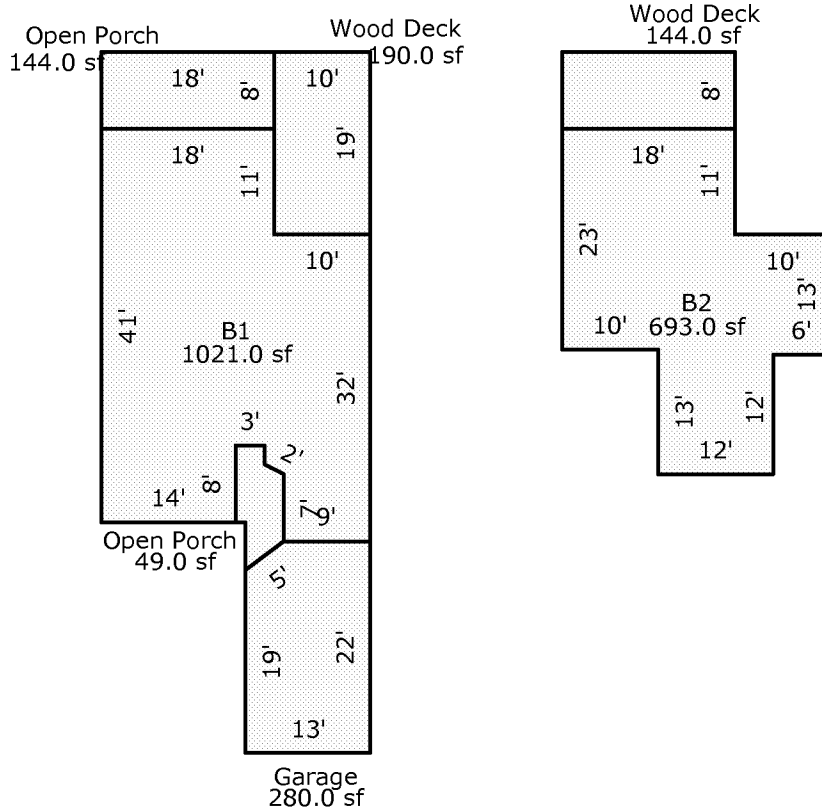

Scale: 1 = 20

AREA CALCULATIONS

### AREA CALCULATIONS SUMMARY

Code	Description	Factor	Net Size	Perimeter	Net Totals
B1	B1	1.00	1021.0	157.2	1021.0
B2	B2	1.00	693.0	128.0	693.0
GA	Garage	1.00	280.0	68.0	280.0
OP	Open Porch	1.00	49.0	33.2	
	Open Porch	1.00	144.0	52.0	193.0
WDECK	Wood Deck	1.00	190.0	58.0	
	Wood Deck	1.00	144.0	52.0	334.0

### Comment Table 1

### Comment Table 2

### Comment Table 3