

SKETCH/AREA TABLE ADDENDUM

SUBJECT	Property Address		
	City	State	Zip
	Owner		
	Client		
	Appraiser Name		

IMPROVEMENTS SKETCH

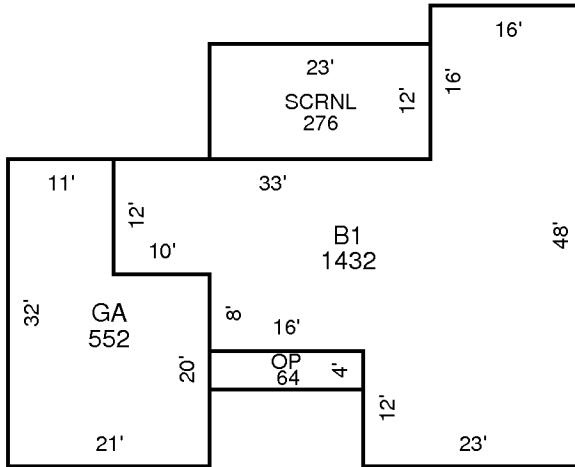

AREA CALCULATIONS

AREA CALCULATIONS SUMMARY					
Code	Description	Factor	Net Size	Perimeter	Net Totals
B1	B1	1.00	1432	194	1432
GA	GA	1.00	552	106	552
OP	OP	1.00	64	40	64
SCRNL	SCRNL	1.00	276	70	276

Comment Table 1	
Comment Table 2	Comment Table 3