

# SKETCH/AREA TABLE ADDENDUM

DATE 11-10-09

RE # 2459895

SUBJECT

PARCEL ID 24 352551 C 2				
CITY COCOA	COUNTY BREVARD	STATE FL	ZIP 32926	
PERMIT # 08BC06220				
MARKET AREA 07	ADDRESS 3718 CHAMBERS LN UNIT 2			
APPRAISER NAME DZC	BRANCH OFFICE TITUSVILLE			

IMPROVEMENTS SKETCH

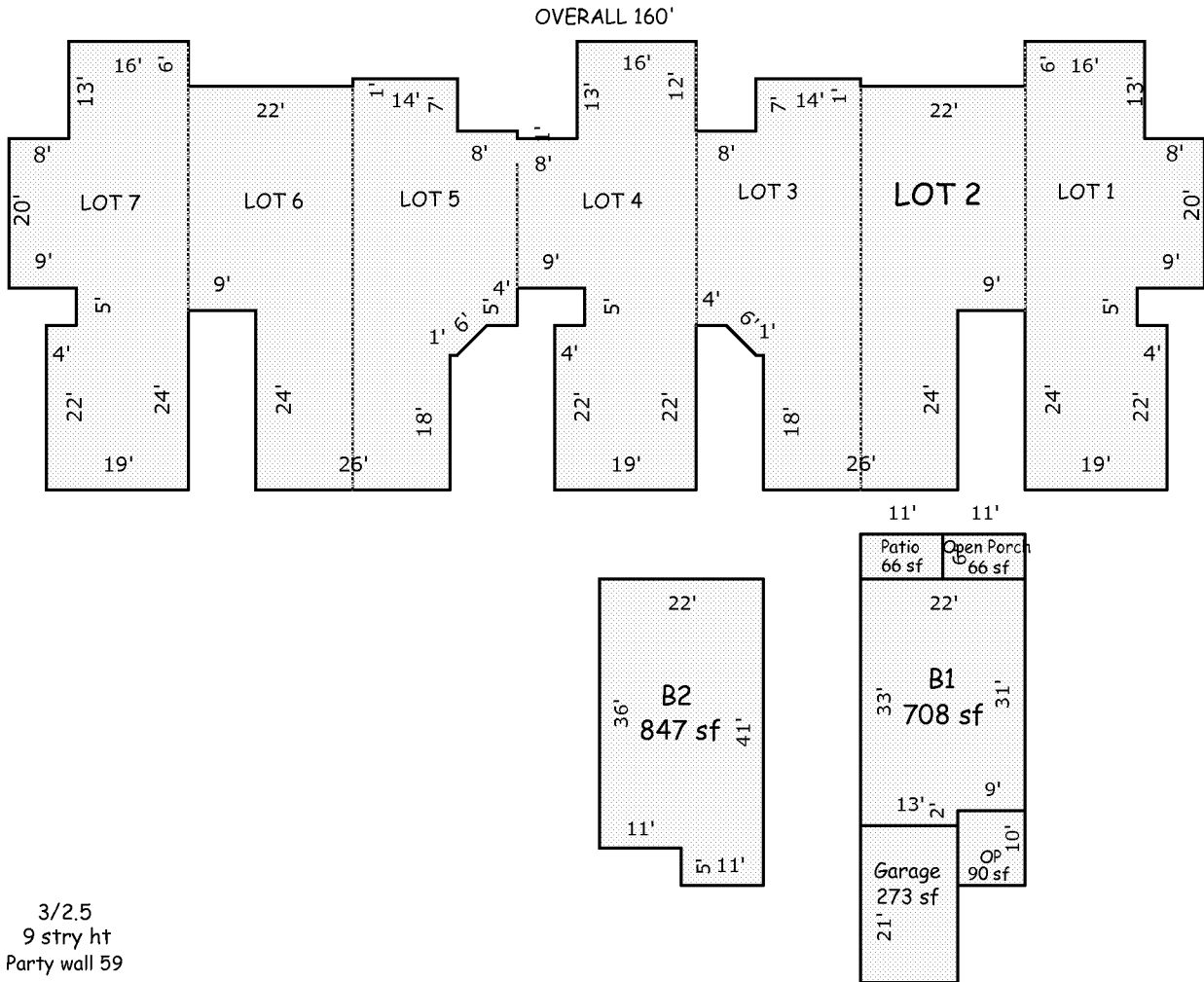

Scale: 1 = 25

AREA CALCULATIONS

### AREA CALCULATIONS SUMMARY

Code	Description	Factor	Net Size	Perimeter	Net Totals
B1	B1	1.00	708	110	708
B2	B2	1.00	847	126	847
GA	Garage	1.00	273	68	273
OP	OP	1.00	90	38	
	Open Porch	1.00	66	34	156
PT	Patio	1.00	66	34	66

### Comment Table 1

--	--

### Comment Table 2

### Comment Table 3

--	--