

SKETCH/AREA TABLE ADDENDUM

File No 24559701

SUBJECT

Property Address 24-36-03-85-X-39			
City	County BREVARD	State	Zip
Owner SFR 12-19-01 OCO120676 \$130,000			
Client		Client Address 555 LIMERICK DRIVE	
Appraiser Name GLENN LEGGE		Inspection Date VIERA (PERMITS)	

IMPROVEMENTS SKETCH

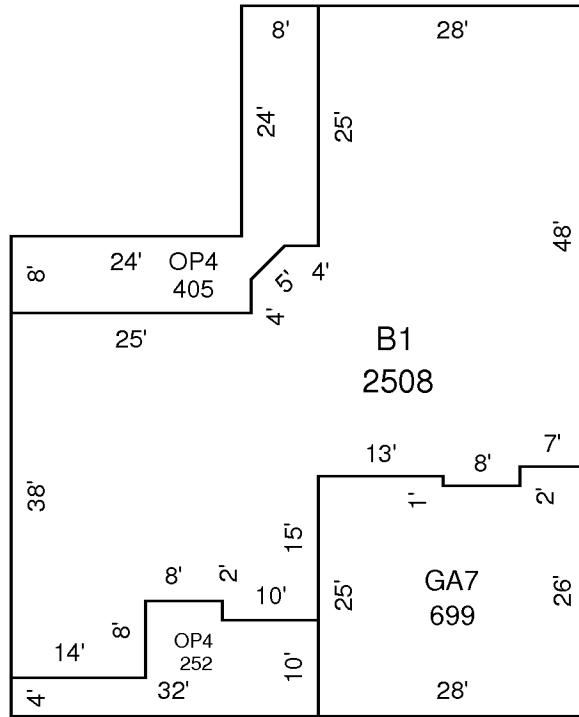

DRAWN: GNL 4-9-02

AREA CALCULATIONS

AREA CALCULATIONS SUMMARY

Code	Description	Factor	Net Size	Perimeter	Net Totals
B1	B1-100	1.00	2508	264	2508
GA7	GA-60	1.00	699	110	699
OP4	OP-30	1.00	252	88	
	OP-30	1.00	405	126	657