

SKETCH/AREA TABLE ADDENDUM

SUBJECT	PARCEL ID 2424317		
	CITY	STATE	ZIP
	PERMIT # 9/22/11		
	MARKET AREA		
	APPRAISER NAME JXS		

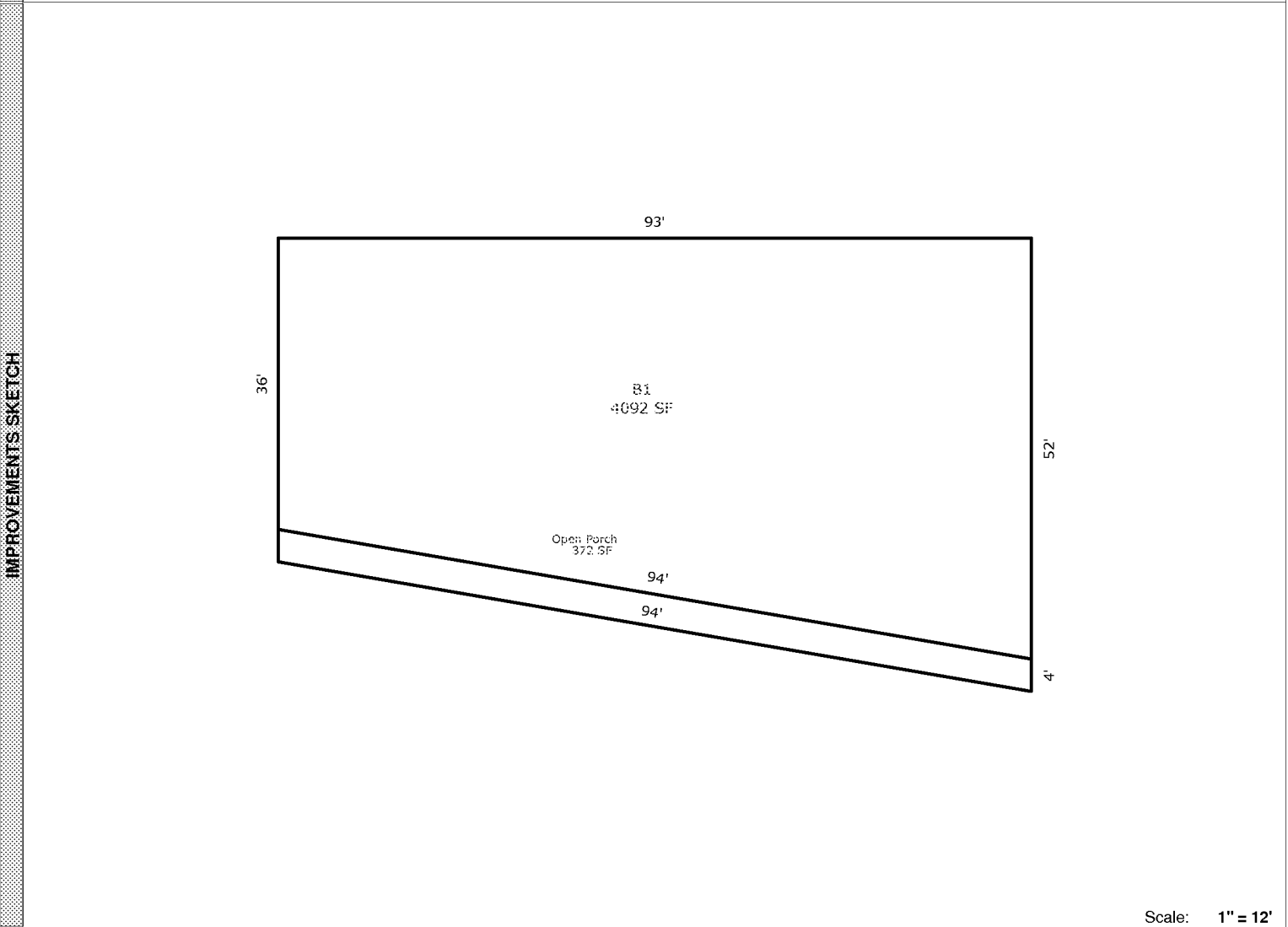

Scale: 1" = 12'

AREA CALCULATIONS SUMMARY						Comment Table 1	
Code	Description	Factor	Net Size	Perimeter	Net Totals		
B1	B1	1.00	4092	275	4092		
OP	Open Porch	1.00	372	197	372		
						Comment Table 2	Comment Table 3