

SKETCH/AREA TABLE ADDENDUM

SUBJECT	PARCEL ID 2414010		
	CITY	STATE	ZIP
	PERMIT # 8/9/11		
	MARKET AREA		
	APPRAISER NAME JXS		

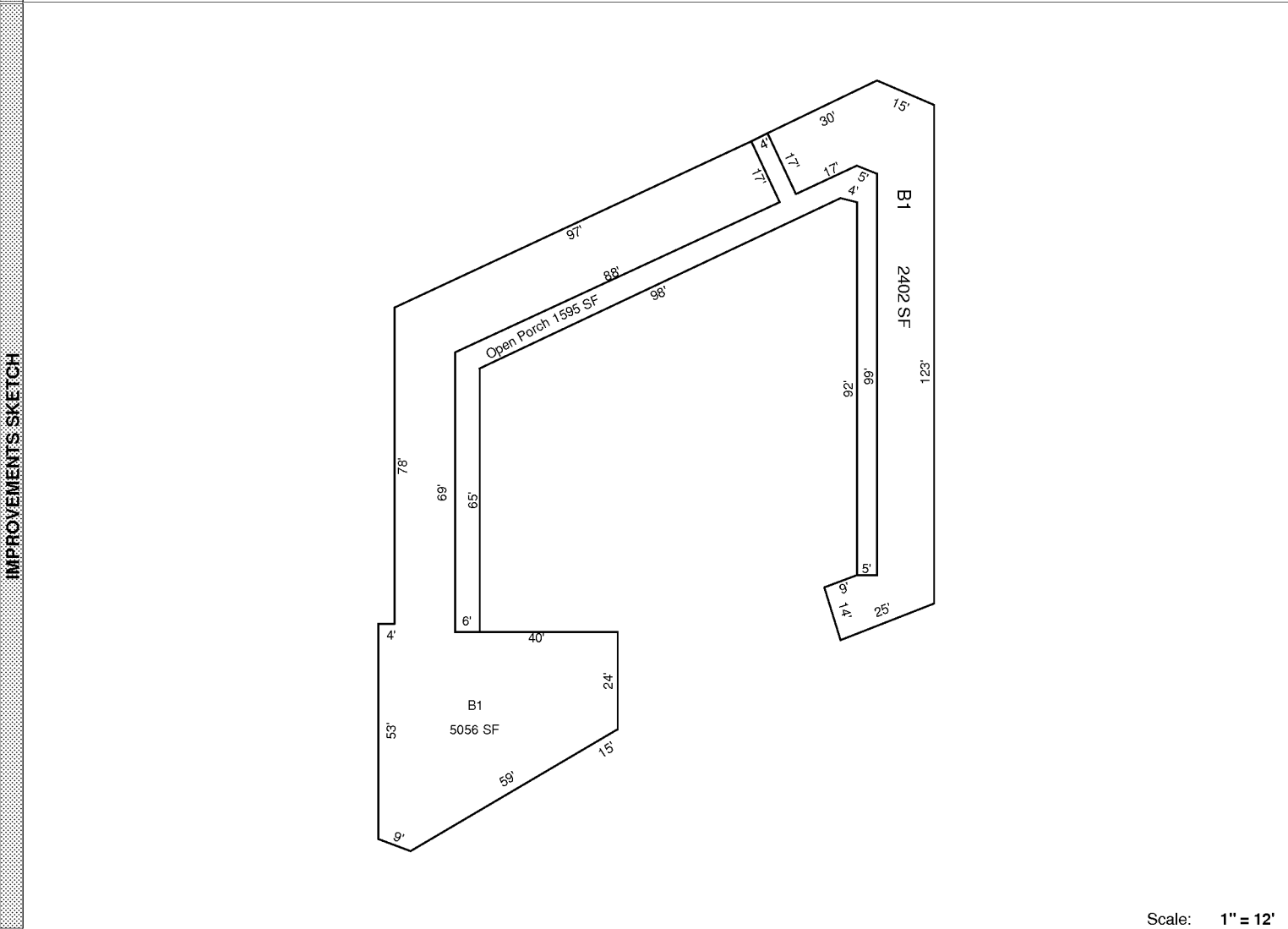

Scale: 1" = 12'

AREA CALCULATIONS SUMMARY						Comment Table 1	
Code	Description	Factor	Net Size	Perimeter	Net Totals		
B1	B1	1.00	5056	537			
B1	B1	1.00	2402	358	7458		
OP	Open Porch	1.00	1595	586	1595		
						Comment Table 2	Comment Table 3