

SKETCH/AREA TABLE ADDENDUM

File No 24130711

SUBJECT

Property Address 24-36-14-79 14

City _____ State _____

Zip _____

Owner SFR 12-30-99 OCOO92576 \$110,000

Client _____ Client Address 202 SYKES LOOP DRIVE

Appraiser Name GLENN LEGGE Inspection Date VIERA (PERMITS)

IMPROVEMENTS SKETCH

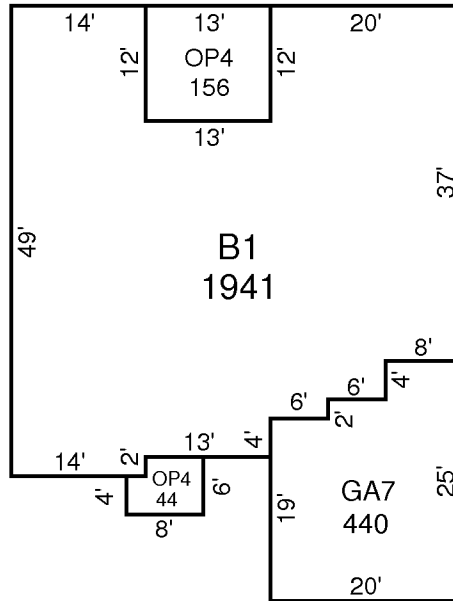

DRAWN: GNL 3-15-00

AREA CALCULATIONS

AREA CALCULATIONS SUMMARY

Code	Description	Factor	Net Size	Perimeter	Net Totals
B1	B1-100	1.00	1941	216	1941
GA7	GA-60	1.00	440	90	440
OP4	OP-30	1.00	44	28	
	OP-30	1.00	156	50	200