

SKETCH/AREA TABLE ADDENDUM

Property Address

City State

Zip

Owner

Client

Appraiser Name

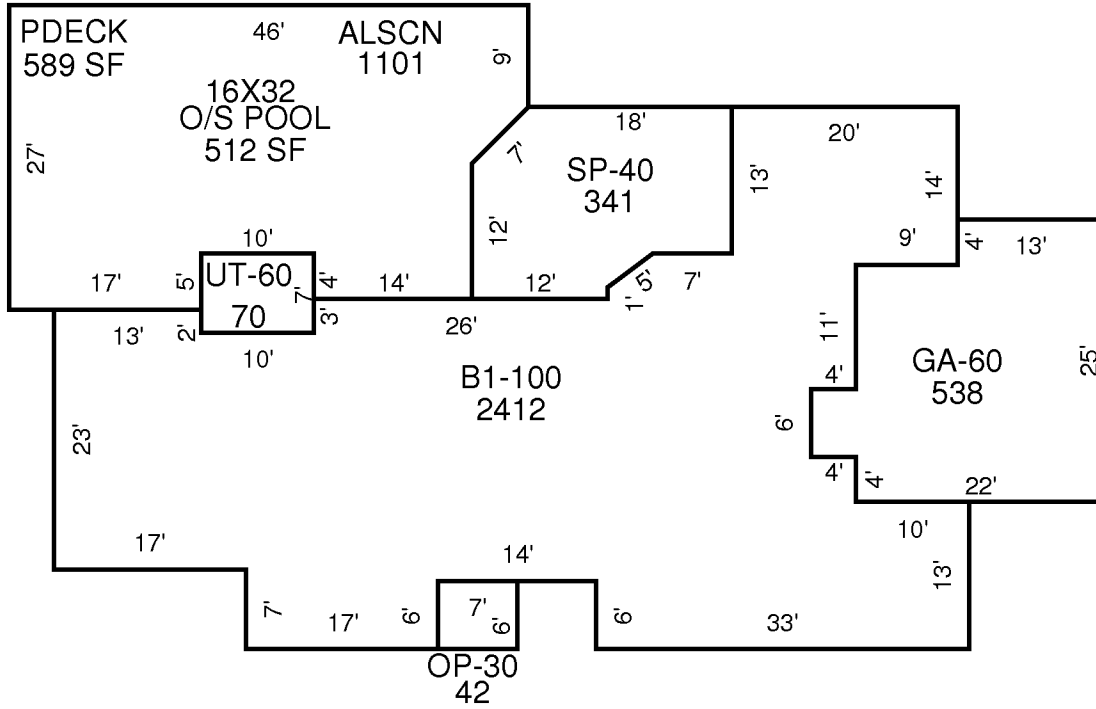

AREA CALCULATIONS SUMMARY

Code	Description	Factor	Net Size	Perimeter	Net Totals
B1	B1-100	1.00	2412	298	2412
GA7	GA-60	1.00	538	102	538
OP4	OP-30	1.00	42	26	42
SP4	SP-40	1.00	341	75	341
UT7	UT-60	1.00	70	34	70
PDECK	PDECK	1.00	1101	151	1101

Comment Table 1

--	--

Comment Table 2

Comment Table 3

--	--