

SKETCH/AREA TABLE ADDENDUM

SUBJECT	Property Address	
	City	State Zip
	Owner	
	Client	
	Appraiser Name	

IMPROVEMENTS SKETCH

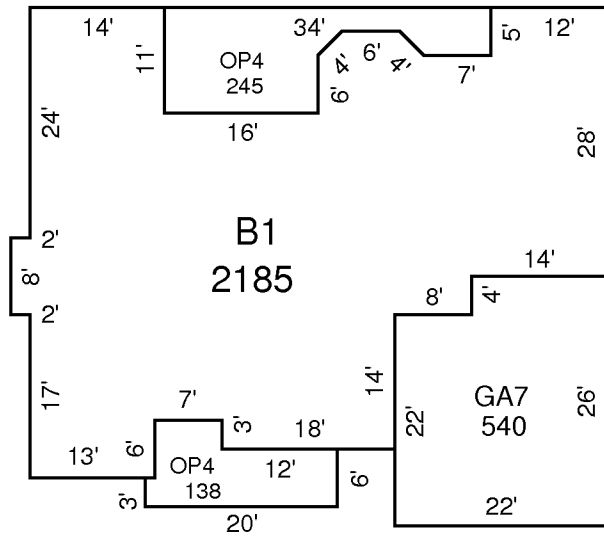

DRAWN: GNL 8-29-00

AREA CALCULATIONS

AREA CALCULATIONS SUMMARY					
Code	Description	Factor	Net Size	Perimeter	Net Totals
B1	B1-100	1.00	2185	252	2185
GA7	GA-60	1.00	540	96	540
OP4	OP-30	1.00	138	58	
	OP-30	1.00	245	92	383
