

SKETCH/AREA TABLE ADDENDUM

File No 24015921

SUBJECT

Property Address	24-35-03-75-1-10		
City	County	BREVARD	State
Owner	SFR 6-29-01 OCO112846 \$70,000		
Client	Client Address 4095 SEVILLE AVENUE		
Appraiser Name	GLENN LEGGE	Inspection Date	VIERA (PERMITS)

IMPROVEMENTS SKETCH

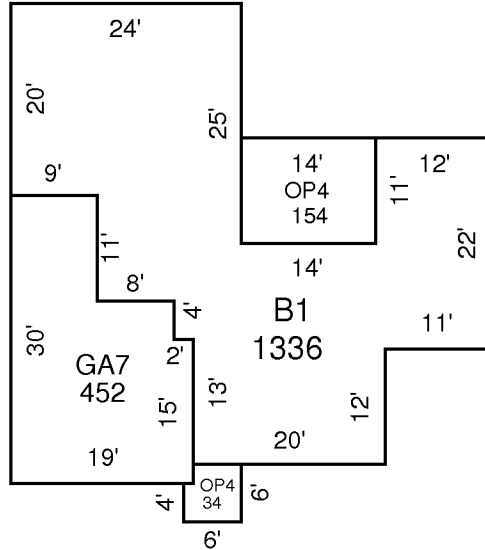

DRAWN: GNL 8-1-01

AREA CALCULATIONS

AREA CALCULATIONS SUMMARY

Code	Description	Factor	Net Size	Perimeter	Net Totals
B1	B1-100	1.00	1336	218	1336
GA7	GA-60	1.00	452	98	452
OP4	OP-30	1.00	34	24	
	OP-30	1.00	154	50	188