

# SKETCH/AREA TABLE ADDENDUM

File No 23204010

SUBJECT

Property Address	23-35-15-01-B-22	
City	State	Zip
Owner	SFR 8-13-98 OCOO75622 \$96,8	
Client	Client Address 7392 BUMELIA DRIVE	
Appraiser Name	GLENN LEGGE	Inspection Date MELBOURNE

IMPROVEMENTS SKETCH

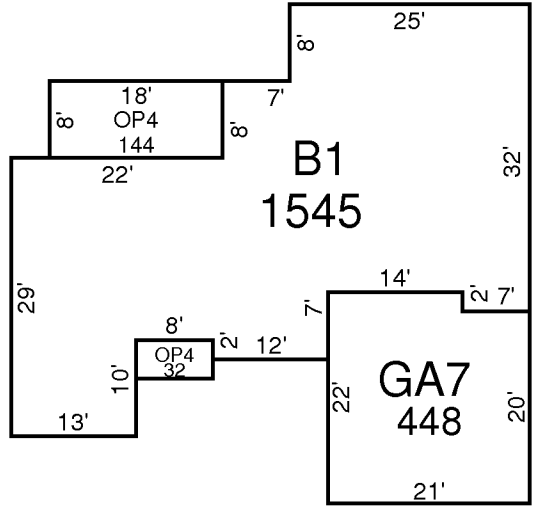

DRAWN: GNL 2-5-99

AREA CALCULATIONS

AREA CALCULATIONS SUMMARY					
Code	Description	Factor	Net Size	Perimeter	Net Totals
B1	B1-100	1.00	1545	206	1545
GA7	GA-60	1.00	448	86	448
OP4	OP-30	1.00	32	24	
	OP-30	1.00	144	52	176
