

# SKETCH/AREA TABLE ADDENDUM

File No 23125600

SUBJECT

Property Address	23-35-28-JN-174-1	
City	State	Zip
Owner	SFR 9-22-98 OCOO77374 \$50,000	
Client	Client Address 6290 EAST BALSAM STREET	
Appraiser Name	GLENN LEGGE	Inspection Date VIERA (PERMITS)

IMPROVEMENTS SKETCH

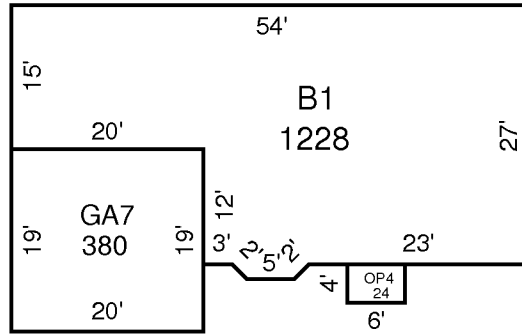

DRAWN: GNL 9-27-99

AREA CALCULATIONS

## AREA CALCULATIONS SUMMARY

Code	Description	Factor	Net Size	Perimeter	Net Totals
B1	B1-100	1.00	1228	163	1228
GA7	GA-60	1.00	380	78	380
OP4	OP-30	1.00	24	20	24