

SKETCH/AREA TABLE ADDENDUM

File No 23065470

SUBJECT

| | | |
|------------------|--|-----------------------|
| Property Address | 23-35-21-JX-195-1 | |
| City | State | Zip |
| Owner | SFR 9-23-98 OCOO76618 \$90,300 1-28-99 | |
| Client | Client Address 6189 BRANT STREET | |
| Appraiser Name | GLENN LEGGE | Inspection Date VIERA |

IMPROVEMENTS SKETCH

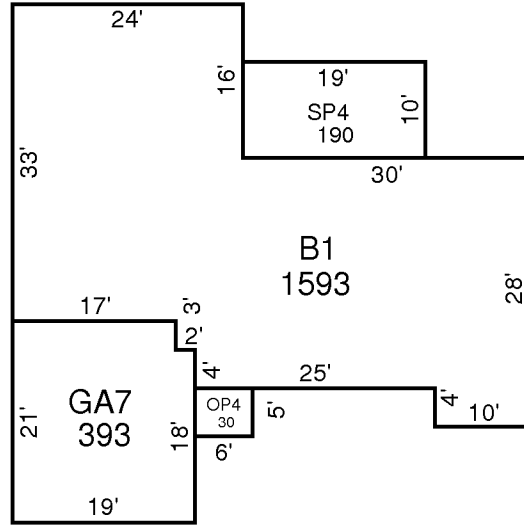

DRAWN: GNL 5-11-99

AREA CALCULATIONS

AREA CALCULATIONS SUMMARY

| Code | Description | Factor | Net Size | Perimeter | Net Totals |
|------|-------------|--------|----------|-----------|------------|
| B1 | B1-100 | 1.00 | 1593 | 196 | 1593 |
| GA7 | GA-60 | 1.00 | 393 | 80 | 393 |
| OP4 | OP-30 | 1.00 | 30 | 22 | 30 |
| SP4 | SP-40 | 1.00 | 190 | 58 | 190 |