

# SKETCH/AREA TABLE ADDENDUM

DATE 3-10-11

RE # 2304853

SUBJECT

PARCEL ID	23 3515JY 226 1		
CITY	COCOA	COUNTY	BREVARD
		STATE	FL
PERMIT #	NONE		
MARKET AREA	04	ADDRESS	7155 KIMBALL AVE
APPRAISER NAME	MAB	BRANCH OFFICE	VIERA

IMPROVEMENTS SKETCH

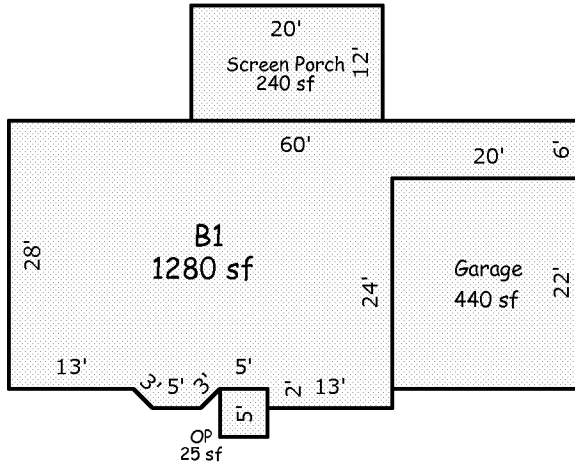

Scale: 1 = 20

AREA CALCULATIONS

### AREA CALCULATIONS SUMMARY

Code	Description	Factor	Net Size	Perimeter	Net Totals
B1	B1	1.00	1280	182	1280
GA	Garage	1.00	440	84	440
OP	OP	1.00	25	20	25
SP	Screen Porch	1.00	240	64	240

#### Comment Table 1

--	--

#### Comment Table 2

#### Comment Table 3

--	--