

SKETCH/AREA TABLE ADDENDUM

File No 2221553

SUBJECT

Property Address	22 35 34 SM 15		
City	TITUSVILLE	County	Brevard
		State	FL
Owner			
Client	Client Address 1158 MEADOW LARK DR		
Appraiser Name	JDI	Inspection Date	MERRITT ISLAND

IMPROVEMENTS SKETCH

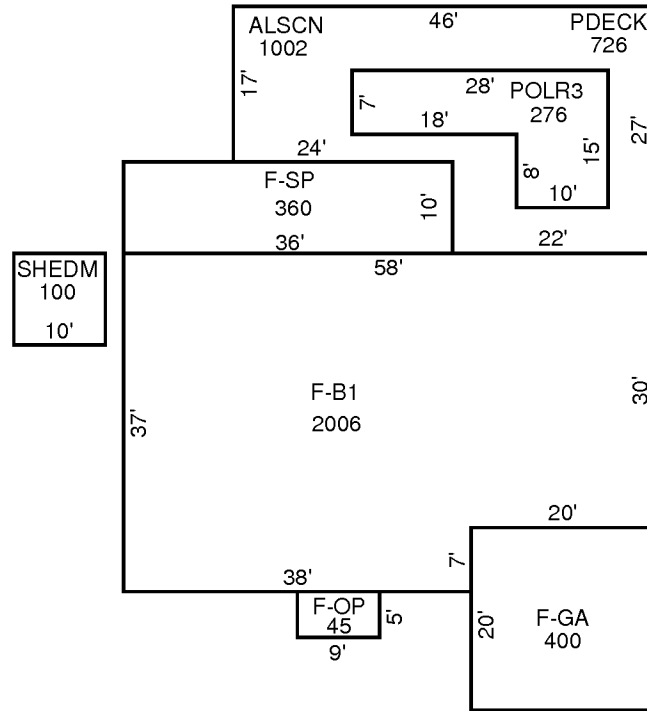

AREA CALCULATIONS

AREA CALCULATIONS SUMMARY

Code	Description	Factor	Net Size	Perimeter	Net Totals
B1	F-B1	1.00	2006	190	2006
GA7	F-GA	1.00	400	80	400
OP4	F-OP	1.00	45	28	45
SP6	F-SP	1.00	360	92	360
ALSCN	ALSCN	1.00	1002	146	1002
PDECK	PDECK	1.00	726	146	726
POOL	POLR3	1.00	276	86	276
SHEDS	SHEDM	1.00	100	40	100

Comment Table 1

--	--

Comment Table 2

Comment Table 3

--	--