

SKETCH/AREA TABLE ADDENDUM

SUBJECT

PARCEL ID	2215663	
CITY	STATE	ZIP
PERMIT #	09/26/11	
MARKET AREA		
APPRAISER NAME	GMT	

IMPROVEMENTS SKETCH

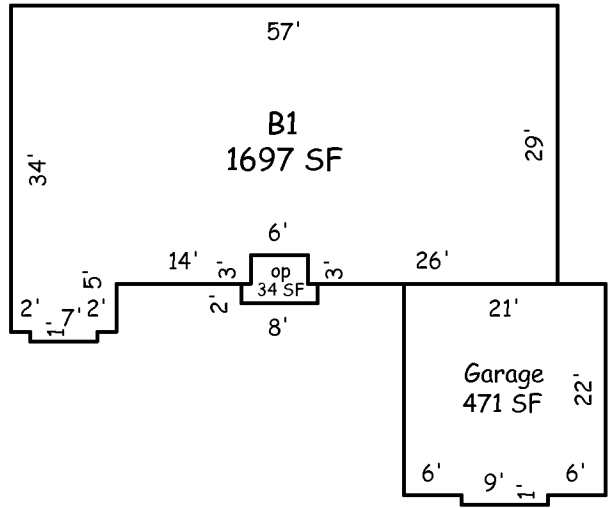

Scale: 1" = 12'

AREA CALCULATIONS

AREA CALCULATIONS SUMMARY

Code	Description	Factor	Net Size	Perimeter	Net Totals
B1	B1	1.00	1697	190	1697
GA	Garage	1.00	471	88	471
OP	op	1.00	34	26	34

Comment Table 1

--	--

Comment Table 2

--

Comment Table 3

--