

SKETCH/AREA TABLE ADDENDUM

RE # 2209770

SUBJECT	PARCEL ID 2209770	CITY TITUSVILLE	COUNTY BREVARD	STATE FL	ZIP 32780
	PERMIT # 11-1-11				
	MARKET AREA 03	ADDRESS 4170 HEMLOCK LN			
	APPRaiser NAME DZC				

IMPROVEMENTS SKETCH

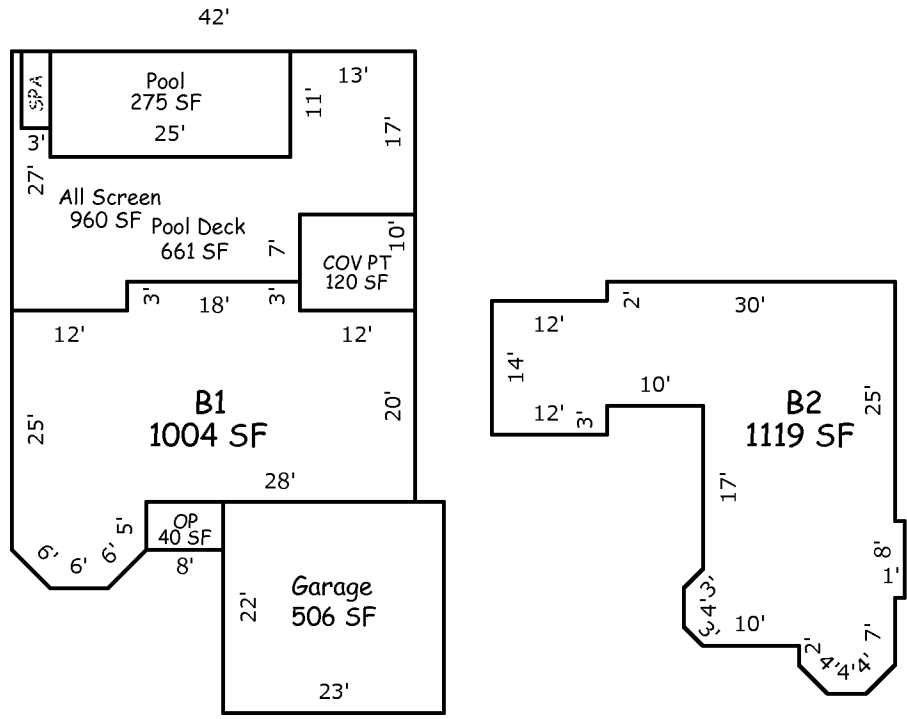

Scale: 1" = 12'

AREA CALCULATIONS

AREA CALCULATIONS SUMMARY

Code	Description	Factor	Net Size	Perimeter	Net Totals
B1	B1	1.00	1004	143	1004
B2	B2	1.00	1119	176	1119
GA	Garage	1.00	506	90	506
OP	OP	1.00	40	26	40
ALSCN	All Screen	1.00	960	138	960
COVPT	COV PT	1.00	120	44	120
PDECK	Pool Deck	1.00	661	160	661
POOL	Pool	1.00	275	72	275

Comment Table 1

--

Comment Table 2

--

Comment Table 3

--