

SKETCH/AREA TABLE ADDENDUM

DATE 3-24-11

RE # 2106739

SUBJECT

PARCEL ID 21 353000 794				
CITY TITUSVILLE	COUNTY BREVARD	STATE FL	ZIP 32796	
PERMIT # none				
MARKET AREA 03	ADDRESS 1150 War Eagle Blvd.			
APPRAISER NAME DZC	BRANCH OFFICE Titusville			

IMPROVEMENTS SKETCH

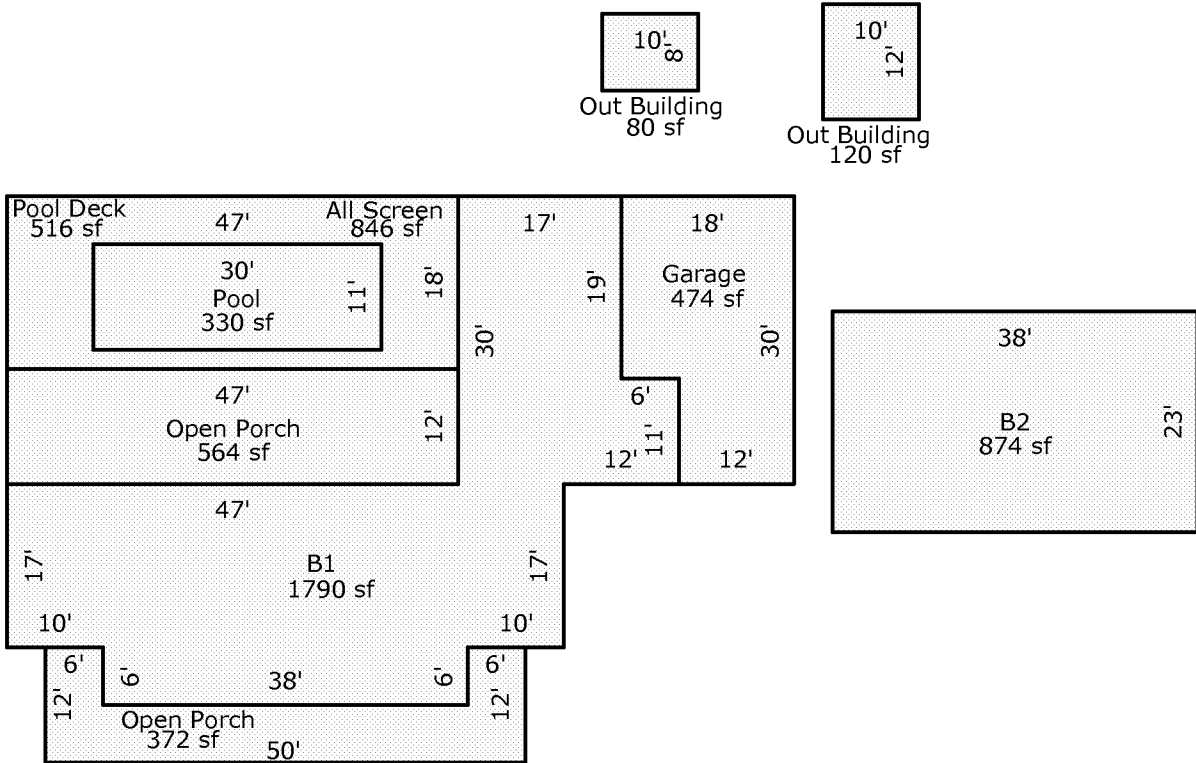

Scale: 1 = 20

AREA CALCULATIONS

AREA CALCULATIONS SUMMARY

Code	Description	Factor	Net Size	Perimeter	Net Totals
B1	B1	1.00	1790	246	1790
B2	B2	1.00	874	122	874
GA	Garage	1.00	474	96	474
OP	Open Porch	1.00	564	118	
	Open Porch	1.00	372	136	936
ALSCN	All Screen	1.00	846	130	846
OBLD	Out Building	1.00	80	36	
	Out Building	1.00	120	44	200
PDECK	Pool Deck	1.00	516	130	516
POOL	Pool	1.00	330	82	330

Comment Table 1

--	--

Comment Table 2

Comment Table 3

--	--