

SKETCH/AREA TABLE ADDENDUM

Parcel No 2/2/06

File No 2104733

Property Address

City _____ County **Brevard** State **FL** Zip _____

Owner _____

Client _____ Client Address **1990 OLD DIXIE HWY**

Appraiser Name **THERESE LEDUC** Inspection Date **VIERA**

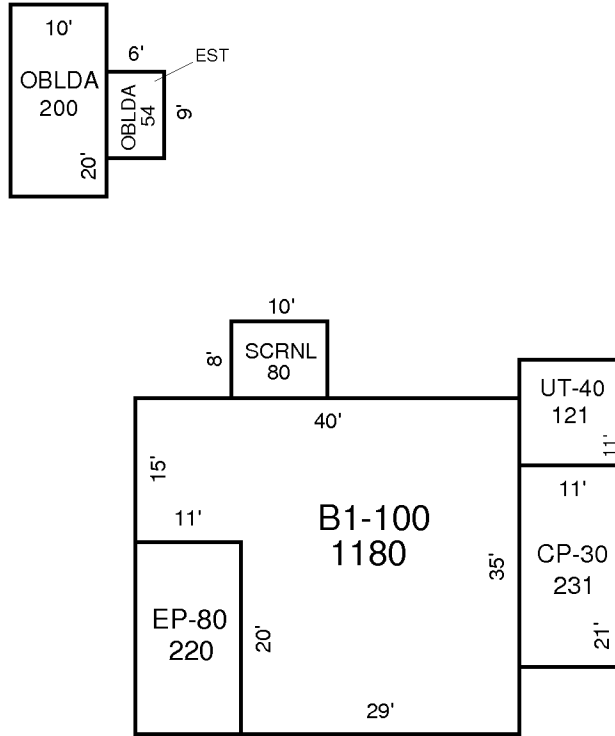

AREA CALCULATIONS SUMMARY

Code	Description	Factor	Net Size	Perimeter	Net Totals
B1	B1-100	1.00	1180	150	1180
EP5	EP-80	1.00	220	62	220
UT3	UT-40	1.00	121	44	121
CP4	CP-30	1.00	231	64	231
OBLDG	OBLDA	1.00	200	60	
	OBLDA	1.00	54	30	254
SCREEN	EMSCRNL	1.00	80	36	80

Comment Table 1

Comment Table 1	
-----------------	--

Comment Table 2

Comment Table 3

Comment Table 2	Comment Table 3
-----------------	-----------------